

AVRii SOL

Avrii SOL Integra

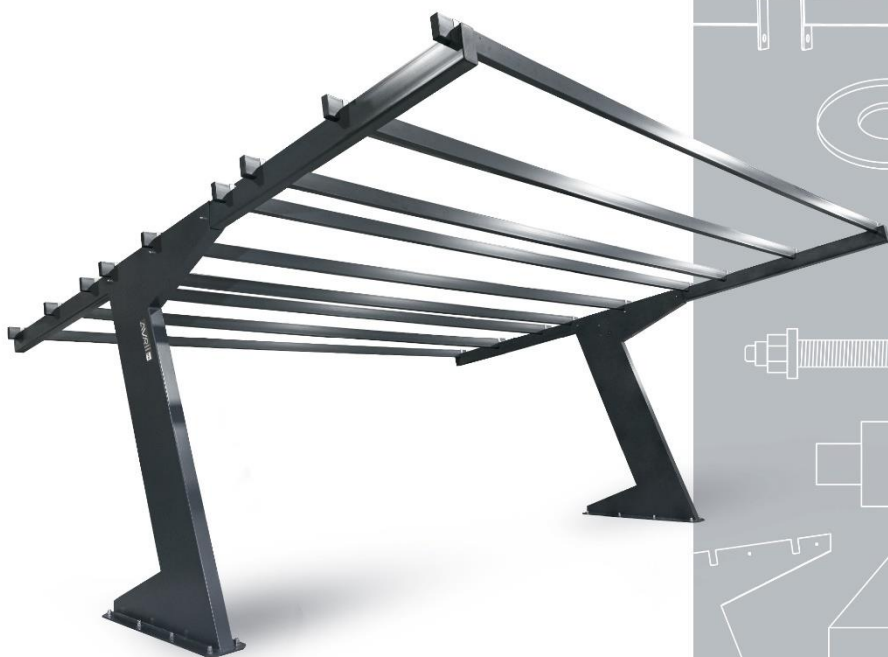

CARPORT Avrii SOL Integra Zcon

ASSEMBLY MANUAL

Version 1.0

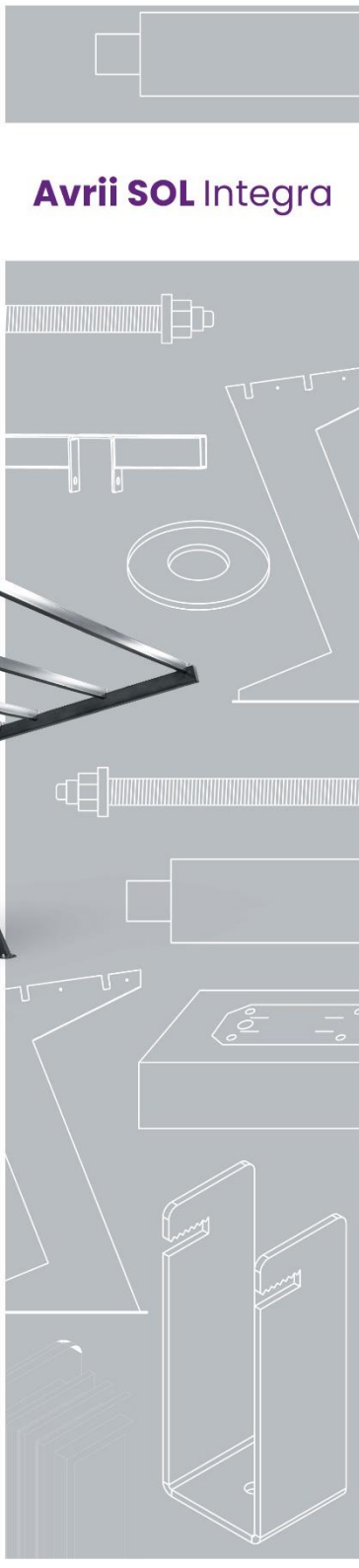

TABLE OF CONTENTS

Introduction	3
Safety resources	4
List of components	5
List of components – Carport Avrii SOL Integra Zcon.....	5
List of components – Carport Avrii SOL Integra Zcon-ext extension	7
Additional accessories – Carport Avrii SOL Integra.....	8
Preparation for assembly	9
Assessment of the assembly site.....	9
Poured foundation	10
Use of a steel brand	10
Assembly of the Avrii SOL Integra Carport Zcon	12
List of tools required for assembly.....	12
Installing the vertical pillars.....	12
Mounting the supporting structure for photovoltaic modules.....	14
Installation of the PV modules	19
Installation of the Carport Avrii SOL Integra Extension	22
NOTES	24

Introduction

This document contains information concerning the construction, installation and safe use of the Avrii SOL Integra Carport Zcon (referred to in the manual simply as the 'carport'). The installation specialist must read and understand the notes and information before installation. Before assembly, installation specialists should acquaint themselves with the mechanical and electric requirements of the set.

Adhere to all EU and domestic provisions concerning the erection and usage of the load-bearing structure as well as the electric equipment and systems. Failure to adhere to the indications provided below can lead to death, bodily injury or property damage.

Any questions you may have should be sent to our sales or technical departments.

The manual constitutes the fundamental source of information on rules concerning the handling, usage, execution of installation and operation as well as the shut-down and disassembly of the relevant technical resources in terms of cooperation with PV modules and electric vehicles.

Information provided in the manual is based on the following:

- norms and provisions of the law as well as good engineering practices,
- mechanical data and parameters of the components and devices,
- data and electrical parameters of the components making up the electrical system,
- knowledge of issues of PV structure robustness,
- conducted analyses and inspections.

In case of discrepancies between the assembly manual and the manual attached to the assembly system or other components of the PV system, immediately seek advice from Avrii specialists or entities authorised by Avrii to release opinions concerning the installation and usage of their products. Following consultations and the acquisition of a technical opinion from authorised entities, it is permitted to develop declarations concerning the modes of special use not covered by the present manual.

The present manual should be stored in a safe manner, to be used in the future (operation and maintenance) as well as in case of disassembly and resale.

We continuously work to improve our products and their documentation. For this reason, we recommend to always use the latest version of the manual.

The instruction applies in the territory of Europe as of October 1, 2024, and replaces all previous versions.

CONTACT DETAILS



Avrii Sp. z o.o.

VAT: PL 9930672075

ul. Mroźna 8A, 33-102 Tarnów, POLAND

- www.avrii.eu
- info@avrii.eu
- +48 14 696 88 89 ext. 6

Safety resources













The adherence to general safety provisions at all times during installation and maintenance work as well as during inspections guarantees the maintenance of system efficiency and reduces the risk of injuries and trauma.





Installers should adhere to health and safety regulations and the resulting recommendations:

- Perform your work so as not to introduce greater risks than those that stem from the object of the work for yourself or any potential bystanders.
- Make use of assembly manuals attached to the relevant components.
- Protect the construction/ installation area in a clearly visible manner, and mark it at a distance that is safe for bystanders.
- Use tools dedicated for the installation of PV systems by authorised manufacturers.
- Have your delegation document to conduct work that you received from your superior at hand.
- Have at their disposal the specific scope of competences related to your knowledge and qualifications.
- Stay informed of the hazards that may be found at your work place.
- At no time should unauthorised personnel be allowed to enter the construction / installation area; by good practices, technical culture and by law, it is absolutely forbidden to endanger bystanders, those not taking part in the assembly.
- Adhere to recommendations of you supervisors or assembly inspectors as they are decision-makers in terms of technical solutions, for immediate introduction of potential improvements and changes with an indication of causes and documentation of the reasons for changes.
- Keep at the construction site all certificates and documents confirming your licences as well as the operating capacity of your equipment (helmets, safety harnesses, ladders, etc.) in order to show them during a possible inspection by authorised supervisory bodies.
- Avoid disadvantageous weather conditions, such as strong winds or precipitation
- Do not work in snowfall or in the presence of ice.

This manual does not list all the precautions necessary for safe operation.

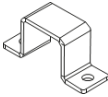
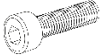
List of components
List of components – Carport Avrii SOL Integra Zcon (structure)

No.	Name	Technical drawing	Pcs.
1.	Structural support leg (vertical support / load bearing structural pillar)		2
2.	Pillar cap		2
3.	Allen screw A2 M6x12		8
4.	Cap nut		16
5.	Oval washer A2 21 (M20)		16
6.	Profile A 160x80x5, length 5500 ⁽¹⁾ mm		2
	Profile A 160x80x5, length 4900 ⁽²⁾ mm		2
7.	Profile B 100x40x3, length 5750 mm		9
8.	End cap 160x80 mm		4
9.	End cap 100x40 mm		18
10.	Threaded rod A2 M10X110		6
11.	Cap nut A2 M10		12
12.	Round washer A2 10,5 (M10)		12

13.	Grip KAB_inox_3 mm		18
14.	Allen screw M8X25 A2		36
15.	Clamp KPV_inox_1,5 mm		90
16.	Push screw M6X16 A2		90
17.	Gasket 20-30 ⁽³⁾ x15x2000 mm		18













⁽¹⁾ Dedicated for Zcon-ve1-00





⁽²⁾ Dedicated for Zcon-ve1-01

⁽³⁾ Depending on the selected model of PV modules

Additionally, a spray can of lacquer is included in the set for potential use in case of damage to the lacquered coating during installation.

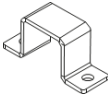
List of components – Carport Avrii SOL Integra Zcon-ext (extension)

No.	Name	Technical drawing	Pcs.
1.	Structural support leg (vertical support / load bearing structural pillar)		1
2.	Pillar cap		1
3.	Allen screw A2 M6x12		4
4.	Cap nut		8
5.	Oval washer A2 21		8
6.	Profile A 160x80x5, length 5500 ⁽¹⁾ mm		1
	Profile A 160x80x5, length 4900 ⁽²⁾ mm		1
7.	Profile B 100x40x3, length 5750 mm		9
8.	End cap 160x80 mm		2
9.	End cap 100x40 mm		9
10.	Threaded rod A2 M10x110		3
11.	Cap nut A2 M10		6
12.	Round washer A2 10,5 (M10)		6

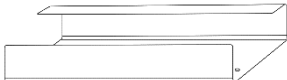
13.	Grip KAB_inox_3 mm		9
14.	Hex screw M8X25 A2		18
15.	Clamp KPV_inox_1,5 mm		90
16.	Push screw M6X16 A2		90
17.	Gasket 20-30 ⁽³⁾ x15x2000 mm		21
18.	Connector for B-profiles		9

⁽¹⁾ Dedicated for Zcon-vel-00

⁽²⁾ Dedicated for Zcon-vel-01

⁽³⁾ Depending on the selected model of PV modules

In the case of extension to additional positions: 4, 6, 8, or 10, the number of components will increase in accordance with the quantities listed in the table above.

Additional accessories – Carport Avrii SOL Integra

Accessories available for purchase from Avrii Sp. z o.o.

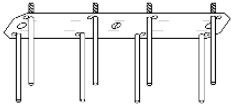
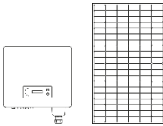
Name	Steel brand for Carport Avrii SOL Integra – to be embedded in the foundation	Components for the PV Set – photovoltaic modules, inverter, protections, cabling
Technical drawing		

Avrii Sp. z o.o. allows the installation of an EV charger on the structural pillar (vertical support). The installation should follow the mounting instructions provided by the EV charger manufacturer and be carried out with minimal interference to the Carport structure and in the designated area for this purpose.

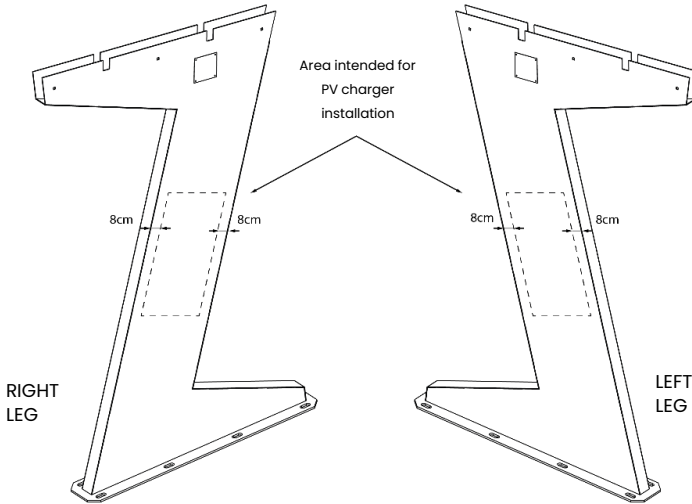

Fig.1 Permitted location for EV charger installation on the vertical support

Preparation for assembly

Assessment of the assembly site

The place of installation should be flat, it may have a slight inclination of up to 5% against ground level. All concrete components should be level so as not to cause shifts against the soil and ensure structure stability.

In order to assess the location of erection of the system (outside of geometric components), and for spatial orientation, analyse this list of additional components influencing the ultimate assessment, such as:

- Pitch
- Azimuth
- Presence of trees, pillars and other high objects
- Distance from other buildings
- Distance from hazardous and endangered zones.

The structure complies with the following snow and wind load standards. To verify the installation of the carport in a specific location, please contact Avrii’s Technical Department.

Permissible snow and wind loads – calculated according to the following standards:

EN 1991-1-3 Eurokod 1
EN 1991-1-4 Eurokod 1

Poured foundation

At the selected spot, following precise measurements and an inspection of diagonals, prepare an **excavation and fit your formwork**. The size of the foundation should be designed by the constructor based on the geologist's opinion regarding the soil and location. The depth of the foundation for the carport depends on several factors, such as soil type, geotechnical conditions, and the carport's design. The foundation depth should be greater than the frost depth but not less than 1 meter.

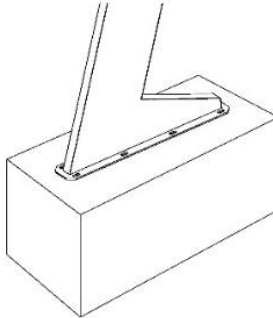

Fig.2. Example drawing of the foundation

The foundation slab should be made of **at least C20/25 concrete with steel rebar** of ribbed rods, min. diameter 10 mm. It is recommended to additionally use transverse connections made of wire with a minimum diameter of 6 mm. Alternatively, with the approval of the constructor, a chemical anchor or other reinforcement may be used.

The horizontal heights of both foundation pieces and their distribution against each other should be the same so that the vertical support posts are placed symmetrically against each other. **It is necessary to check the alignment of the diagonals and the distances between the foundations.** The upper portion of the foundation should be levelled precisely. For this purpose, it is suggested to use a laser level.



For each ordered carport, we provide technical drawings adapted to the photovoltaic modules selected by the customer and the number of spots. The drawings contain detailed guidelines regarding the spacing of the legs and the arrangement of photovoltaic modules and are adapted to the customer's requirements.

Use of a steel brand

To expedite the process of mounting the vertical supports of the carport onto the foundation at Avrii Sp. z o. o. dedicated steel brand for the Avrii SOL Integra Carport are available.

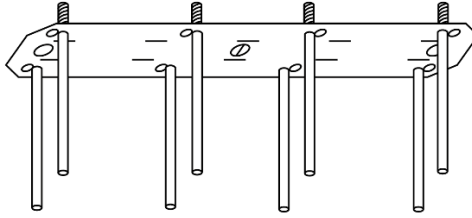

Fig. 3. Steel brand for Carport Avrii SOL Integra

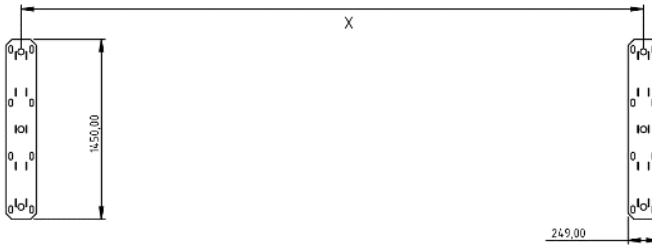

Fig. 4. Arrangement of the steel brands for mounting the Avrii SOL Integra carport

X - distance dependent on the photovoltaic modules used

If steel brand are used for setting the vertical supports of the carport, the following steps should be taken:

- Place the steel brand in the prepared excavation. Level it properly and secure it to prevent any movement during concrete pouring.
- Check the alignment of the diagonals and the distances between the threaded rods.

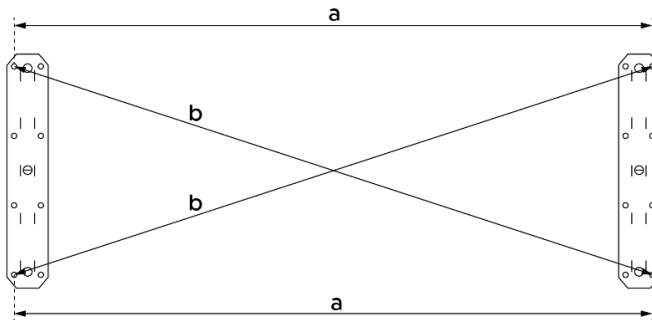

Fig. 5. The diagonals and distances that should be aligned when positioning the steel brand

- Protect threaded rods from concrete contamination.
- The steel brand sheet should be positioned at the intended level for installing the vertical supports of the carport.

Assembly of the Avrii SOL Integra Carport Zcon



To ensure safety and working comfort, assembly should be carried out by a four-person team.

List of tools required for assembly

To ensure proper assembly, prepare the following tools:

- Torque wrench (with a measurement range of 10-100 Nm);
- Open-ended wrench (17 and 30 mm);
- Hex key set (3, 4, and 6 mm);
- Rubber hammer;
- Scissors (for cutting gaskets);
- Laser level;
- Spirit level;
- Retractable tape measure of at least 8 meters;
- Transport strap;
- Scaffold (in case of assembly using a forklift, ladders can be used alternatively);
- Personal protective equipment;
- OPTIONAL - angle grinder or other tool for cutting threaded rods.



To shorten the gaskets, scissors should be used instead of a knife, as this will ensure greater cutting precision and better fitting of the sealing elements.

Installing the vertical pillars

1. **After tying and curing the foundation, you can proceed with installing the vertical supports of the carport.** For this purpose, **recheck the levels** (if steel brands are used, this applies to their levels) and clean the top surface of the foundation and threaded rods. If any deviations are observed, **additional washers and nuts** can be used to level out the differences between the levels.

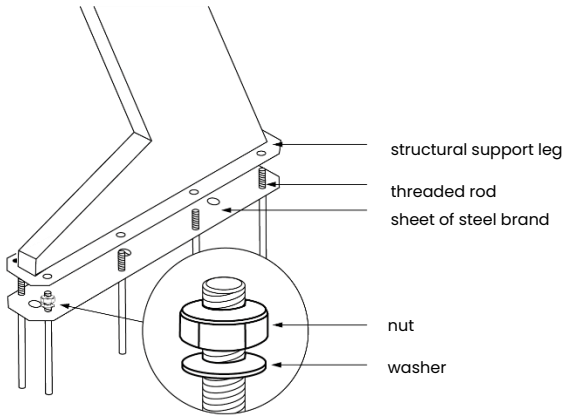

Fig. 6. Placement of washers and nuts for leveling if needed

2. The vertical supports are fixed to the threaded M20 rods protruding from the foundation. The supports should be faced towards the entry direction (see fig. 7), and the caps should be found on the inner side of the carport. A forklift can be used for transporting, positioning, and assembling the vertical supports on the foundation.

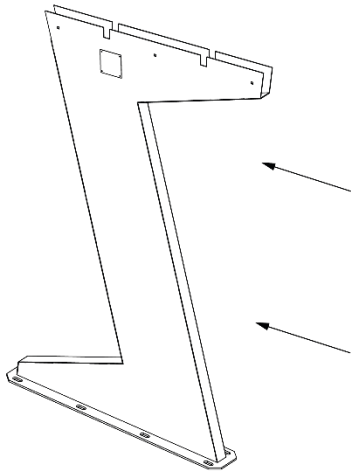

Fig. 7. Method of installing vertical support posts

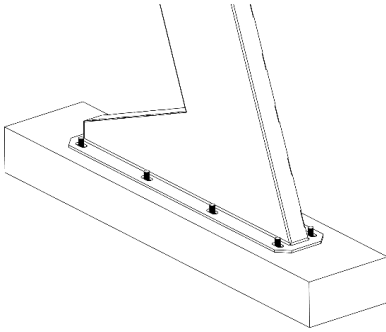

Fig. 8. Installation of the vertical support on the foundation

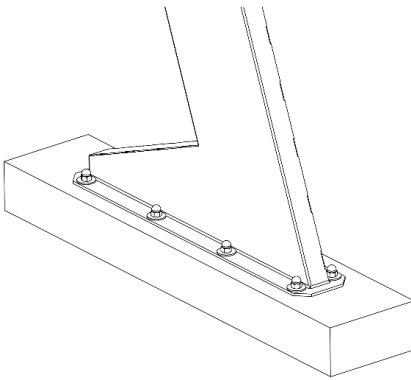

Fig. 9. Screwing the vertical support to the foundation base

3.

The prepared foundation should have the **support placed** on it so that the threaded rods are precisely aligned with the mounting holes of the vertical support.

4.

Using M20 cap nuts along with washers, **secure the leg** to the foundation base. The tightening torque for M20 nuts should be approximately **100 Nm** on average.

Mounting the supporting structure for photovoltaic modules

5. Before proceeding with the further assembly, **check the spacing between the vertical supports** relative to each other and whether they are installed in a vertical position. In case of deviation from vertical, appropriate adjustments should be made (see Fig. 6).

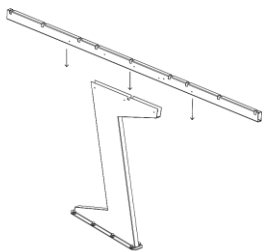

Fig. 10. Method of mounting Steel Profile A to the vertical support

6.

Insert the profile A into the recess of the vertical support. To avoid scratches on the surfaces of joined elements, protective film should be applied.



CAUTION – the profile should be inserted evenly to the level of the top part of the pillar.

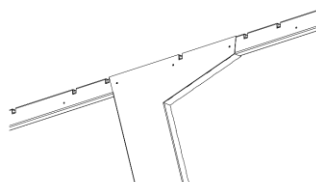

Fig. 11. Proper placement of Profile A in the vertical support

7.

Adjust the connection point of the two elements so that the mounting holes align with the mounting holes of the supporting post.

8.

Place M10 washer onto the M10 threaded rod and tighten the nut. **Thread the prepared rod through the hole.** Then, place washers and tighten the nuts on the other side of the rod using a wrench. Tighten the nuts with an average force of **20-30 Nm**.

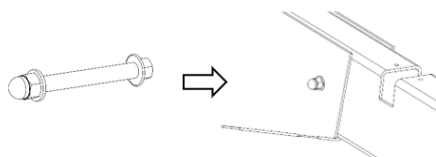

Fig. 12. Preparation and installation of Profile A with the vertical support

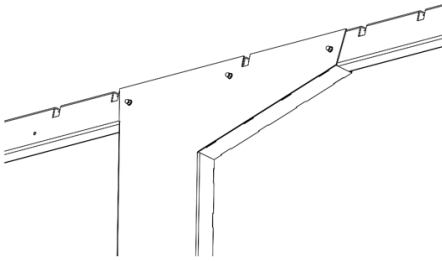

Fig.13. Correct fastening of Profile A with the vertical support

9.

Tighten Steel Profile A to the support post using **3 threaded rods** A2 M10x110 with cap nuts, using washers on both sides.

10. **Measure the distances** between the installed profiles.

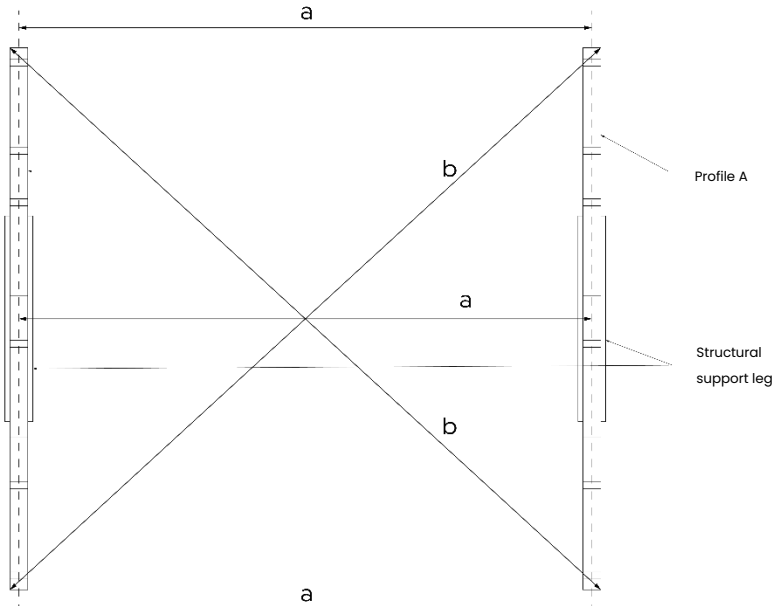

Fig. 14. Diagonals and distances that should be aligned after placing Steel Profile A.

11. Special fasteners enable quick assembly of the transverse B Profiles to the A Profiles using stainless steel brackets and M8x25 hex screws in the dedicated cutouts of Profile A. Profiles B should be mounted **symmetrically** in relation to the vertical supports.

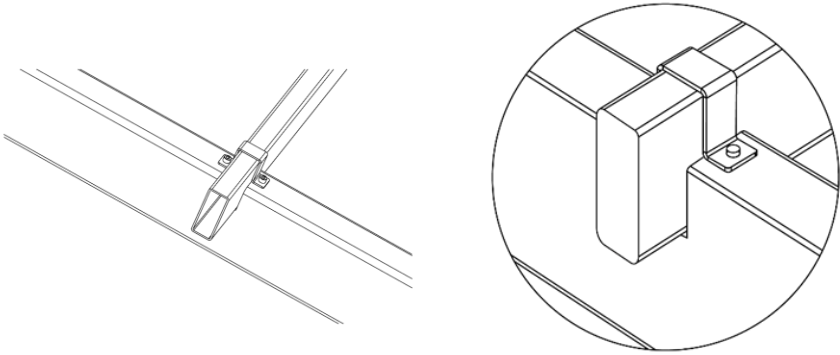

Fig. 15. Attaching Profile B to Profile A

12. Install the external Profile B first. In this step, once again check the distances and diagonals.

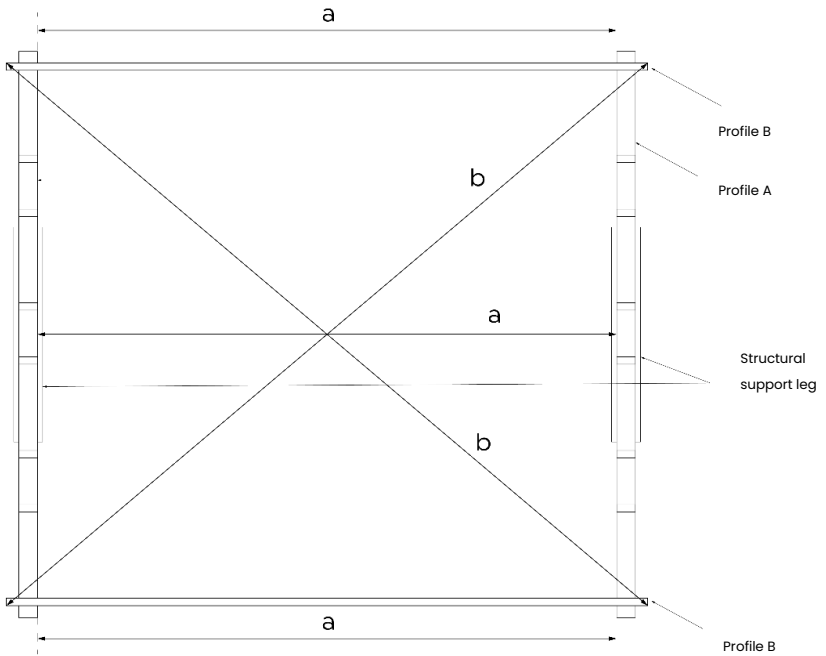

Fig. 16. Diagonals and distances that must align after positioning Profile A and the outer Profile B elements

13.

Next, **install the end caps** onto Profiles A and B using a rubber hammer with gentle force.

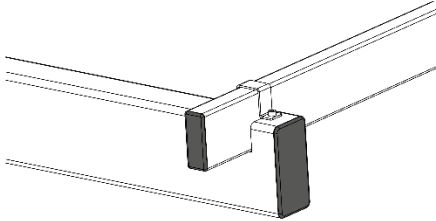

Fig. 17. Installation of end caps for the profiles.

14.

A structure prepared in this **manner is ready for the installation of PV modules** and other components. In case of damage to the paint coating during installation, a spray can of paint in the same color is included with each set to mask or paint over the damaged areas.

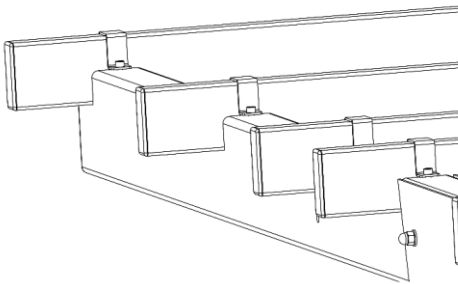

Fig. 18. Correctly assembled structure

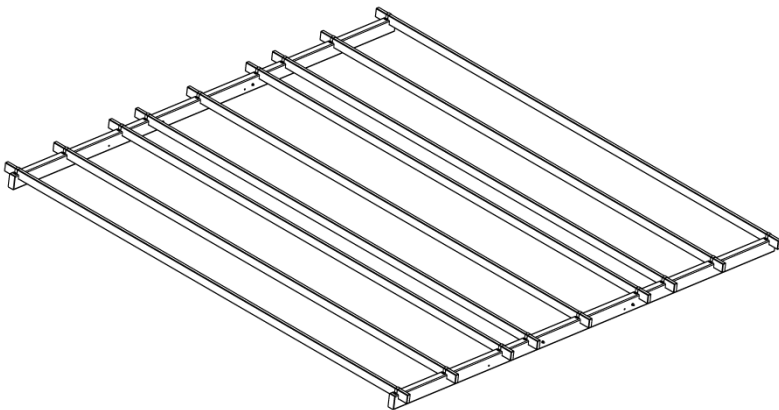

Fig.19 Structural matrix made of A and B profiles

Installation of the PV modules

1. Before proceeding with the installation of the photovoltaic modules, plan their placement on the roof in accordance with best practices for designing photovoltaic systems. Also check the required support points for the installed modules in the manufacturer’s installation manual. The modules on the carport, as a whole, should be centered with respect to the transverse B profiles. With this premise in mind, plan any necessary offset of the first and end modules from the edges of the B profiles.

The installation of the modules is performed on the longer side using specially designed clamps. Starting from the side edge of the carport, the first module should be placed on the lower side of Profile A. The mounting involves securing the base of the module’s support frame and Profile B with a clamp, then tightening an M6x16 A2 screw. The torque should average between 15 to 20 Nm.

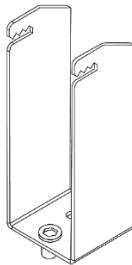

Fig. 20. Clamp KPV_inox_1.5 mm

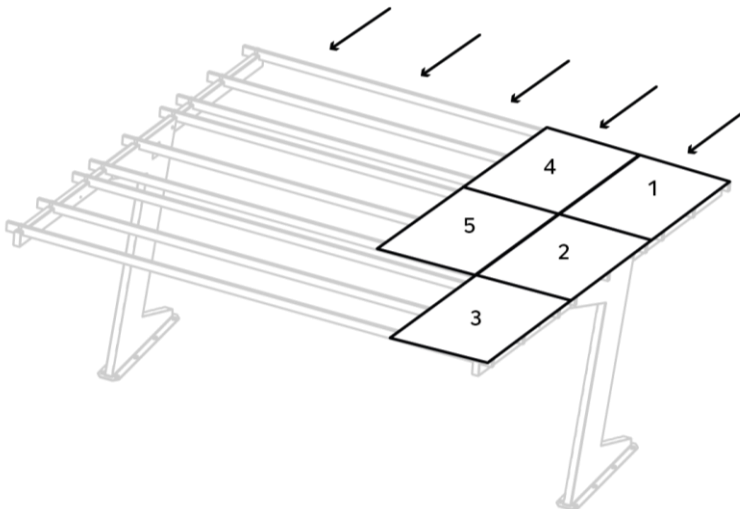

Fig. 21. Correct sequence for mounting modules on the structure.

2. A crucial aspect during the assembly of a carport with modules is the **precise attachment of gaskets to the modules**. This has the greatest impact on the watertightness of the structure.

Before installing each module, **attach the gasket to one shorter side of the frame**, on the side where the next module will be mounted. **Trim the gasket with scissors** so that it protrudes about two to three millimeters beyond the module frame on both sides.



NOTE – Remember not to stretch the gasket during installation, as it should naturally return to its original shape, ensuring a proper seal.

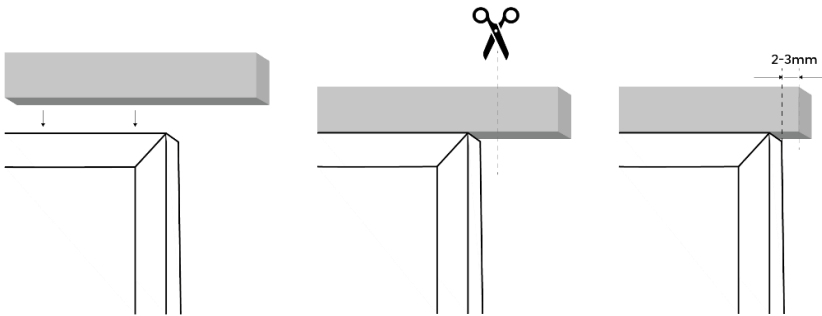

Fig. 22. Attaching the gasket to the shorter frame of the module

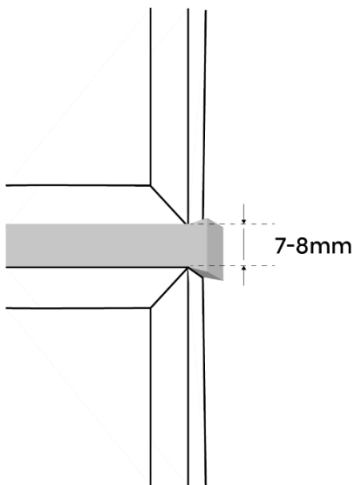

Fig. 23. Proper pressing of the gasket between the modules

3.

Modules with gaskets should be pressed manually so that the distance between them is approximately 7-8 mm. It is not recommended to use woodworking clamps or other tools that could damage the module frames.

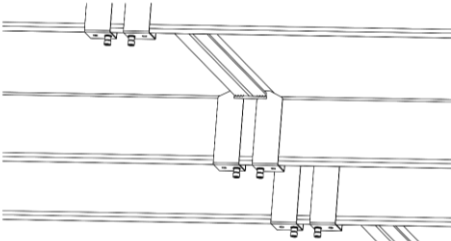

Fig. 24. Mounting the modules to the carport structure

4.

Mount the module mounting clamps to the profile **from below**, sliding the notch of the clamp onto the base of the module frame. Then, tighten the push screw. The torque should average around **15 Nm**. Continue to install subsequent modules along the carport support, directing towards the higher side of the structure.

5.

After installing the first row of modules, **a gasket should be attached along the longer sides, along the entire length, on the side of the next row of modules**. The longest possible lengths of gaskets should be used to minimize the number of connections (e.g., three segments of gasket, each 2 m long). It should connect all the longer sides of the row of modules. **The installation of subsequent rows proceeds in the same manner.**

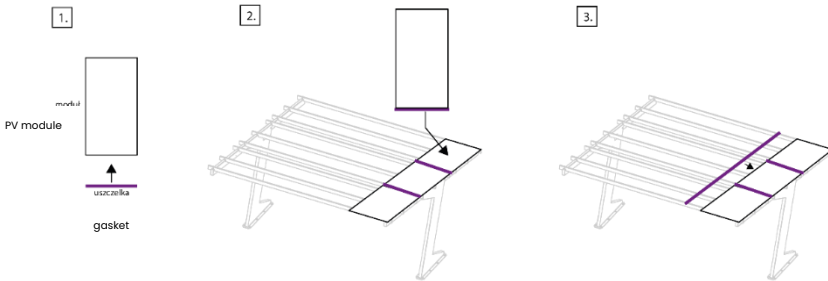

Fig. 25. Proper method for installing gaskets on photovoltaic modules:

- 1 – Attach the gasket to the shorter side of the module
- 2 – Install modules with gaskets onto the structure.
- 3 – Secure the gasket along the entire length of the longer sides of the modules.

After installing the final row, **check the pressing of the gaskets**. If any irregularities or gaps occur, you can easily adjust the module installation. Each of them is secured with independent clamps.

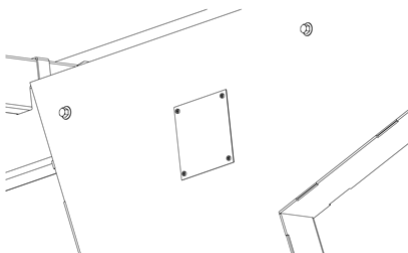

Fig. 26. Installation of caps on the inspection openings

6.

After verifying the placement of the modules and their tightness, **correctly make the electrical connections between the modules**. Then, cover the inspection opening with the included cap.

It is suggested to route the cables through a cable gland, which can be mounted in the cap beforehand.

Installation of the Carport Avrii SOL Integra Zcon-ext

There is an option to extend the Carport Avrii SOL Integra Zcon with additional parking spaces using the Carport Avrii SOL Integra Zcon-ext product. The extension systems require designing the length of Profile B according to the installed photovoltaic modules and the width of the parking spaces.

Dedicated connectors are provided for joining Profiles B together. They are included with every carport order with an extension.

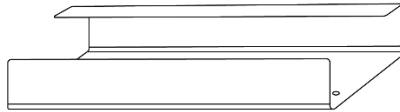

Fig. 27. Connector for B-profiles

The connector should be inserted halfway into the end opening of Profile B from the side where the carport extension is planned.

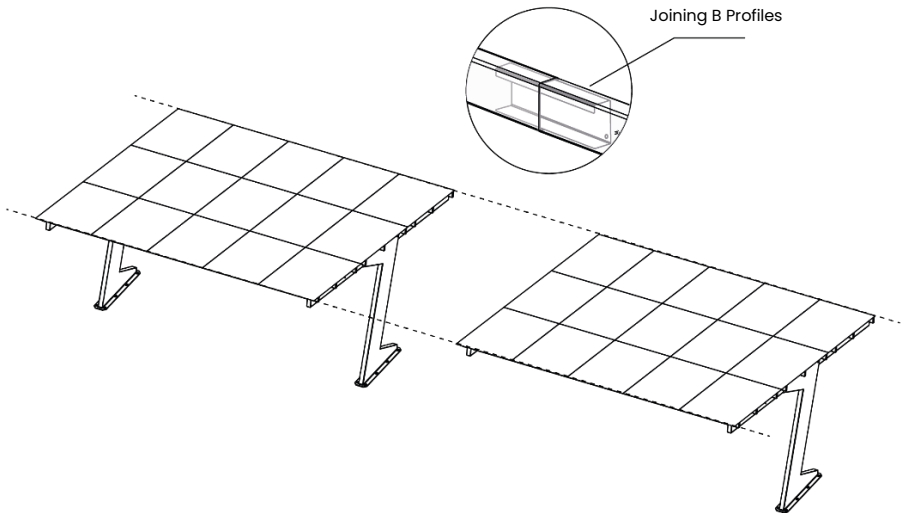

Fig. 28. Extension of the Carport Avrii SOL Integra Zcon

To secure the connector, you can use a screw as shown in Figure 29.

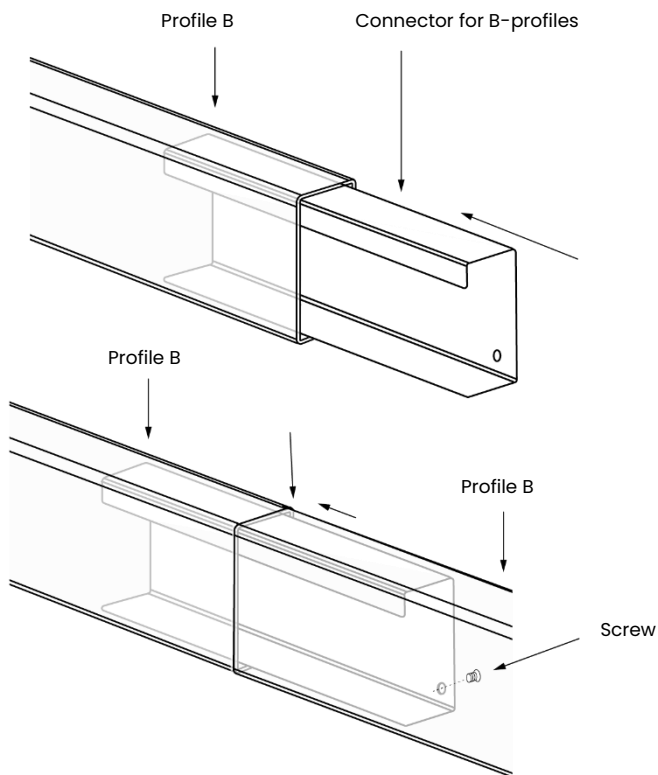

Fig. 29. Method of connecting Profiles B using the Connector

If you have any questions regarding the correct assembly of the Carport Avrii SOL Integra, please contact the manufacturer – **Avrii Sp. z o.o.**

NOTES

.....

.....

.....

.....

.....

.....

.....

.....

.....

.....

.....

.....

.....

.....

.....

.....

.....

.....

.....

.....

.....

.....

.....

